



## Three-ring Micro Powder Mill

# 三环微粉磨

### 用途及适用范围

三环微粉磨可对高岭土、石灰石、方解石、大理石、滑石、重晶石、石膏、白云石、膨润土、云母、叶腊石、海泡石、硅藻土、石墨、明矾石、萤石、钾长石、磷矿石、颜料等湿度小于6%，莫氏硬度不大于6级的百余种非易燃易爆物料进行超细粉加工。成品粒度325-2500目（0.044-0.005mm）。

### 工作原理

主机电动机通过减速器带动主轴及转盘旋转，转盘通过柱销带动几十个环辊在磨环滚道内滚动并旋转。大块物料经锤式破碎机破碎成小颗粒后由提升机送入储料仓，电磁振动给料机将物料均匀地送到转盘上部的散料盘上，物料在离心力的作用下散向圆周边，并落入磨环的滚道内被环辊冲压、碾磨、研磨而粉碎，物料经第一层粉碎后落入第二层及第三层，高压离心风机的抽吸作用将外部空气吸入机内，并将粉碎后的物料带入选粉机内。选粉机内旋转的涡轮使粗颗粒物料回落重磨，细粉则随气流进入旋风集粉器并由其下部的卸料阀排出即为成品，而带有少量细粉尘的气流则经过脉冲除尘器净化后通过风机和消声器排出。



## Three-ring Micro Powder Mill

### 性能特点

1. 高效节能: 在成品细度及电动机功率相同的情况下，比气流磨、搅拌磨、球磨机的产量高一倍以上。
2. 易损件使用寿命长: 磨辊、磨环采用特殊材料制成，一般情况下使用寿命在一年以上，加工碳酸钙、方解石时，使用寿命可达三年以上。
3. 安全可靠: 因磨腔内无滚动轴承和螺钉，所以不存在轴承及其密封件易损的问题，也不存在螺钉易松动而毁坏机器的问题。
4. 清洁、环保: 采用脉冲除尘器和消声器，大大降低了粉尘污染和噪音，达到了国家的环保标准。

### 主要技术参数 / Main Specifications

项目 Item	环辊 数量	工作 直径	滚道环 数量	最大进 料粒度	成 品 粒 度	产 量	主 机 功 率	外 形 尺 寸
型号 Model	Roller Numbers (pcs)	Ring Diameter (mm)	Ring Numbers (pcs)	Max. Feeding Size(mm)	Output size (mm)	Capacity (kg/h)	Motor Power (Kw)	Overall Dimension (mm)
CZM60	15	∅ 600	1	10	0.044-0.005	350-2500	37	10000×2500×5500
CZM80	21	∅ 800	1	10	0.044-0.005	600-4500	55	13000×3000×6400
CZM100	27	∅1000	1	10	0.044-0.005	900-6500	110	18000×4000×8300

注：技术数据如有变动，恕不另行通知。

Note: Any Change of technical data shall not be advised additionally.

## 三环微粉磨全套设备示意图

Three-ring micro powder mill diagram of the equipment

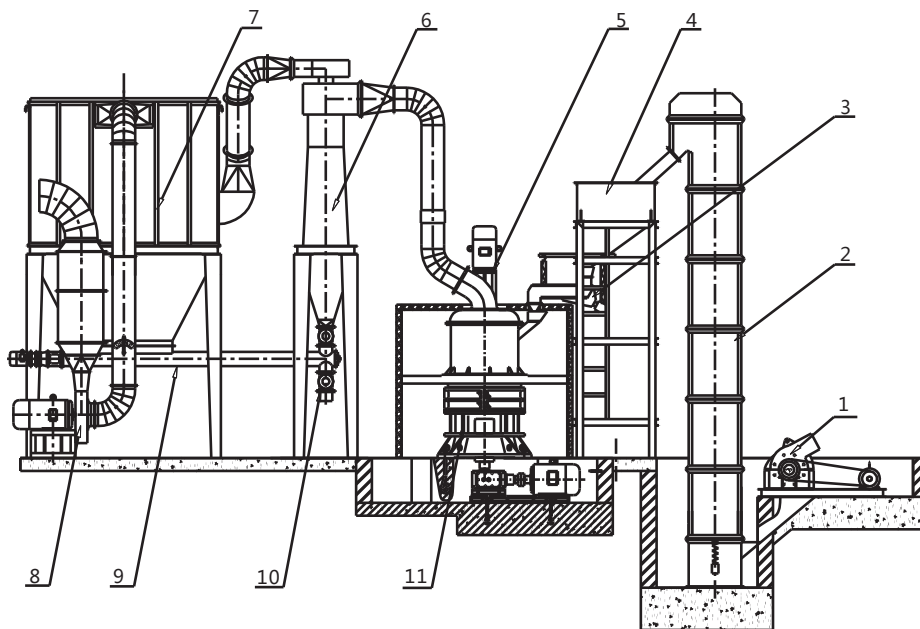

- 1.锤破/ Hammer Crusher
- 2.斗式提升机/ Bucket Elevator
- 3.振动给料机/ Vibrating Feeder
- 4.料仓/ Hopper
- 5.分级器/ Classifier
- 6.集粉机/ Power Collector
- 7.除尘器/ Dust-Catcher
- 8.高压风机/ Air-Blower
- 9.螺旋输送机/ Screw Conveyor
- 10.排灰机/ Dust Discharging Valve
- 11.主机/ Main Equipment

### Usage and Application

The machine is designed to produce super-fine powder or micro powder of different materials with hardness less than 6 in Moh's scale and humidity less than 6 percent such as kaolin, limestone, calcite, marble, talcum, barite, gypsum, dolomite, bentonite mud, mica, pyrophyllite, sepiolite, diatomite, graphite, alunite, fluorite, potassium feldspar, phosphorite, pigment and so on. The granularity of the end products is 325-2500 meshes (0.044-0.0055mm).

### Working Principle

The motor of main equipment drives the main shaft and dial through reducer, and the dial drives numbers of rollers moving in the ring channels via pins. After being crushed by hammer crusher, big materials become small ones and they are sent to the hopper by elevator. The electromagnetic vibrating feeder sends them to the middle of first layer of dial evenly; the materials will be driven to the edge of dial by centrifugal force and fall into the ring channels and are pressed, crushed and ground by the grinding rings and rollers. After ground in the first layer of the dial, the materials fall into the second and third layer and are crushed and ground. The high pressure centrifugal blower inhales air from the outside and blow the materials from the third layer to powder classifier. The rotating turbo in the powder classifier makes the coarse materials return to the mill and reground, while the fine powder mixed in the air goes into the cyclone collector and is discharged from the bottom via discharge valve. The air with very little powder is purified by pulse dust catcher and discharged by blower and muffler.

### Features

High-efficiency and low consumption  
With the same fineness of end products and motor power, its output is two times higher than that of Jet Mill, Mix Mill, and Ball Mill. Quick-wear parts with longer working life  
The grinding rollers and rings are made of special materials. Generally, their work life is more than one year and it could be as long as two years when processing calcium carbonate.

#### Security and Reliability

Because there are no rolling bearing and bolts in the grinding chamber, the problems of easily damaged bearings and sealings as well as machine damage due to the bolts looseness are avoided.

#### Cleansing and Environment Protection

The adoption of pulse dust collector and muffler reduces the industrial dust pollution and noise, which reaches the National Standard.



Zhengzhou Great Wall Heavy Industry Machinery Co., Ltd.

Add: Crossroad of Jiangshan Road and Kaiyuan Road towards West, Huiji District, Zhengzhou City, China.

Tel: 0086-371-63769782

Fax: 0086-371-63769781

Post Code: 450044

<http://www.greatwallcrusher.com>

E-mail: sales@greatwallcrusher.com